

Installation Engineers Contact Details:			Luminaire Ref / Location							
Name:	Tel:									
Luminaire Details:			Full Recharge Duration 24Hours	Duration: 3hrs	Lamp Type:					
ROUTINE TEST RECORD										
Test Type	Year 1		Year 2		Year 3		Year 4		Year 5	
	Signed	Date	Signed	Date	Signed	Date	Signed	Date	Signed	Date
Functional										
Functional										
Functional										
Functional										
Functional										
Functional										
Functional										
Functional										
Functional										
Functional										
Functional										
3hr Duration										

Dimensions:

Part No.	Description	L (mm)	W (mm)	H (mm)	Weight
431128	Royd Anti Tamper 12W/16W/18W 3CCT Bulkhead	305	305	110	0.96Kg

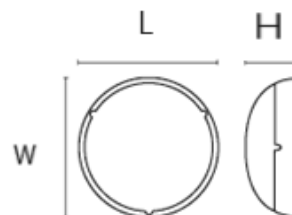

End Of Life Disposal:

Disassembly instructions for end of life disposal available on website.
 Disposal of Electronic Equipment WEEE Directive 2002/96/EC This product falls within the scope of the Waste Electrical & Electronic Equipment Directive (WEEE), which means the product should not be disposed of as normal household waste. Please recycle where facilities exist or check with your Local Authority. RoHS - All components and materials used in this product are RoHS 2002/95/EC compliant. Specifications may change from time to time. The information contained in this leaflet is for guidance only and should not be considered as always accurate and should be treated as not representative.

Installation Instructions



Royd Plug & Play Anti Tamper Bulkhead

Input	220–240V AC 50/60Hz
Power	12W/16W/18W
Operating Temp	-20°C–+40°C
Connection Type	Push-Fit Terminal
Emergency Option	430963 (Sold Separately)
Control Connection	431127 (Sold Separately)
Light Source Energy Rating	D



Box Contents:

- Royd Bulkhead
- Fixing Kit
- Anti-Tamper Tool

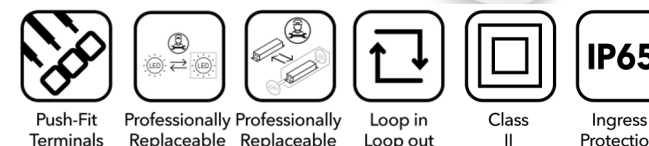

Tools Required For Installation:

- Drill
- Phillips Head Screwdriver
- Wire Strippers/Cutters



READ THESE INSTRUCTIONS THOROUGHLY BEFORE INSTALLATION

KEEP THESE INSTRUCTIONS FOR FUTURE REFERENCE.

IMPORTANT:

This product must be installed by a qualified electrician or competent person, and in accordance with current building and IET wiring regulations.

Warranty:

This luminaire is warranted for a period of 5Years from the date of purchase**. The warranty could be invalidated should the light fitting not be installed according to these instructions, outside the scope of the specification or the product has been altered or tampered with in any way. Please see website for terms and conditions.



WARNING: Risk of electric shock!
Isolate the mains power before proceeding.

- Turn off the mains power before performing inspections, installation, or removal
- Verify that the supply voltage is correct by comparing it with the luminaire label information
- It is the installers responsibility to ensure installation is suitable for the total load of the luminaire(s). The supply cable, fuses/circuit breakers must be correctly rated for the electrical load and considering for any transient inrush currents that may occur.
- Do not perform insulation strength or resistance tests on installed luminaire(s) connected

Wiring instructions for units equipped with EMERGENCY function:

Emergency lighting luminaire must be installed and maintained in accordance with the emergency lighting standard BS 5266-1

- For the emergency unit to work correctly, please ensure that an uninterrupted permanent live feed is present and is connected directly to the 'Permanent Live' terminal of the mains terminal block. Please ensure there are no switches, PIRs etc within the permanent live feed, constant switching of the emergency pack could result in premature battery failure.
- Following power up the green LED indicator should illuminate to indicate charging. If power to the unit is disrupted or isolated, the unit indicating green LED will switch off, triggering the emergency LEDs to illuminate.
- When self-test mode is selected, 24hrs from connection to mains power, a 3hrs duration test will be performed automatically.

Installation Procedure:

1. Using the Tool provided remove Anti-Tamper screws securing the diffuser.
2. Twist the locking tabs and remove the gear tray.
3. Drill correct size holes required through the chosen mounting points in the base.
4. Use grommet provided to your chosen cable entry and pierce, making it Watertight for cable to run through .
5. Connect mains to terminal block as indicated–Standard version.
6. Connect mains to terminal block as indicated–Emergency version.
7. Select colour temperature and power to your desired settings.
8. Replace the geartray , then refit the Diffuser, reconnect the mains supply

1.

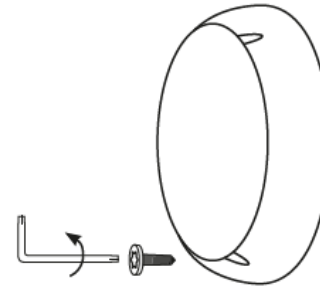

2.

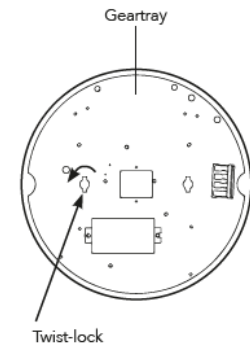

3.

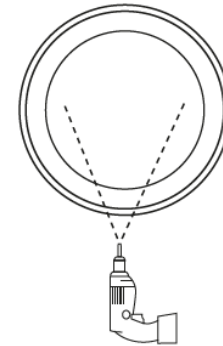

4.

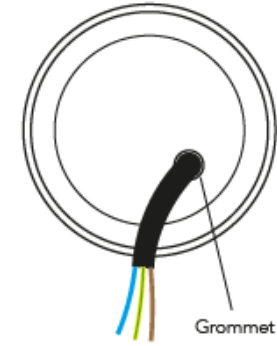

5.

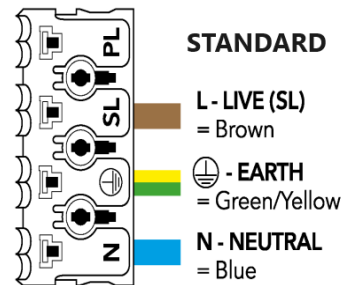

6.

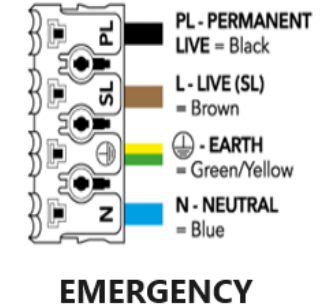

7.

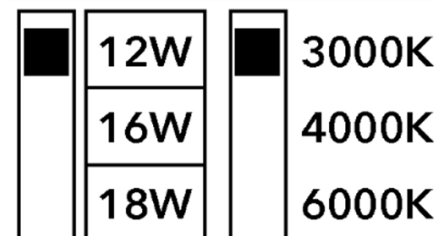

8.

